

# Dollar Bill Butterfly

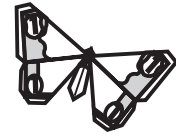

Original design & diagrammed by Michael G. LaFosse  
copyright 1995

This model uses a 2 x 1 format (long sides are twice the length of the short sides) or any rectangle of similar proportions.

Some species of paper money are a good proportion for folding this model without any modifications. Our US Dollar, however, must be converted, by folding, to shorten it to the proper dimensions. You may create dozens of varieties of origami butterflies from this method by experimenting with all kinds of papers, cut or folded to the 2 x 1 proportion.

For square paper use either of the two methods illustrated. Both of these methods produce extra layers of paper on the upper surface of the wings, which may be use to good advantage for the creating of many kinds of patterns on the finished butterfly.

Enjoy!

1. Begin with any US bill. Side facing up will show on the display side of the finished butterfly.

Valley-fold short edge to short edge.

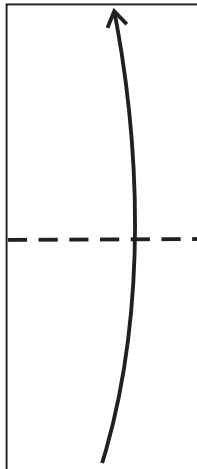

2. Valley-fold the top, raw, short edge to and against one of the long edges. Unfold. The result is a 45-degree angle crease.

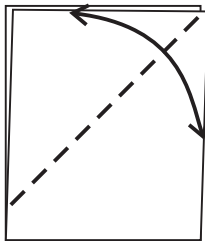

3. Valley-fold the bottom folded edge up. The lower end of the 45-degree angle crease marks the level of this fold. Unfold the entire bill.

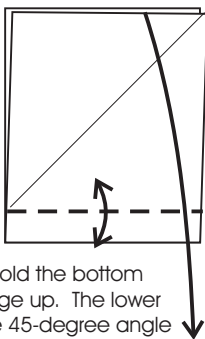

4. You will see three horizontal creases in the center area of the bill. Make the outer two into mountain creases (one already is). Valley-fold these two mountain-fold edges to the center crease line.

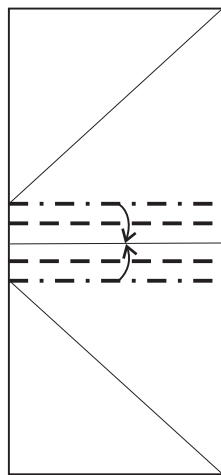

5. This is your 2 x 1 rectangle. Valley-fold the entire shape in half, short edge to short edge.

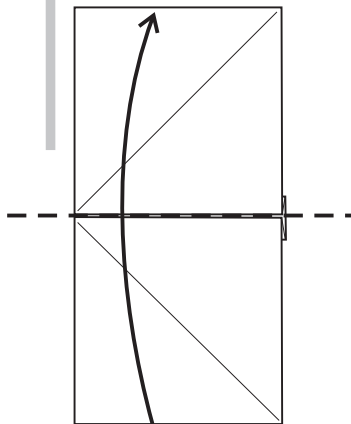

6. Valley-fold in half, right double raw edge to left double raw edge. Notice the thicker, lower edge. This will be absent on 2 x 1 formats which did not require steps 1 - 4 to create.

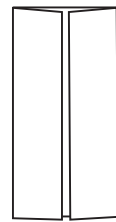
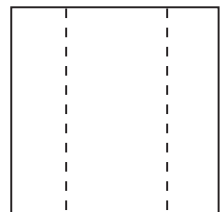
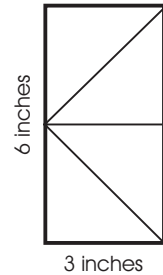
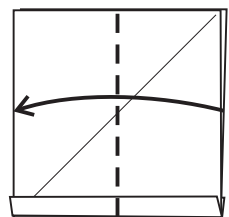

Begin from step 5 if experimenting any of the above, 2 x 1 formats.

# Dollar Bill Butterfly

Designed & diagrammed by Michael G. LaFosse copyright 1995

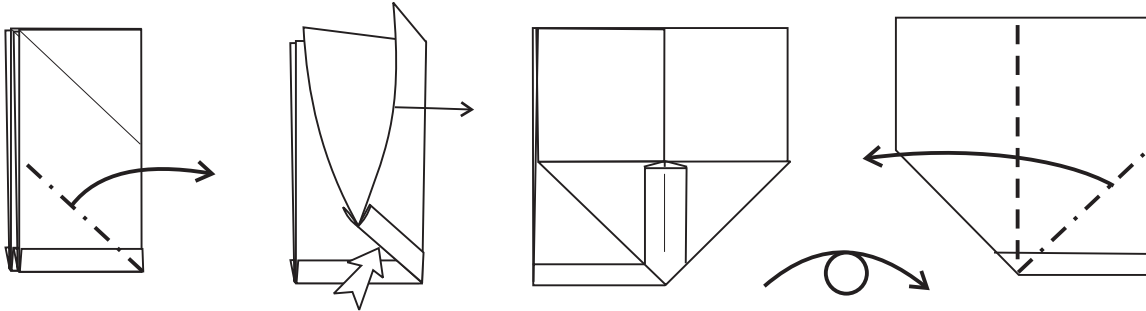

7. Squash fold by lifting the first two layers up and separating them, evenly, to open a triangular pocket. Apply pressure to the layered center edge and press flat to the table.

8. Turn model over and squash-fold the other side.

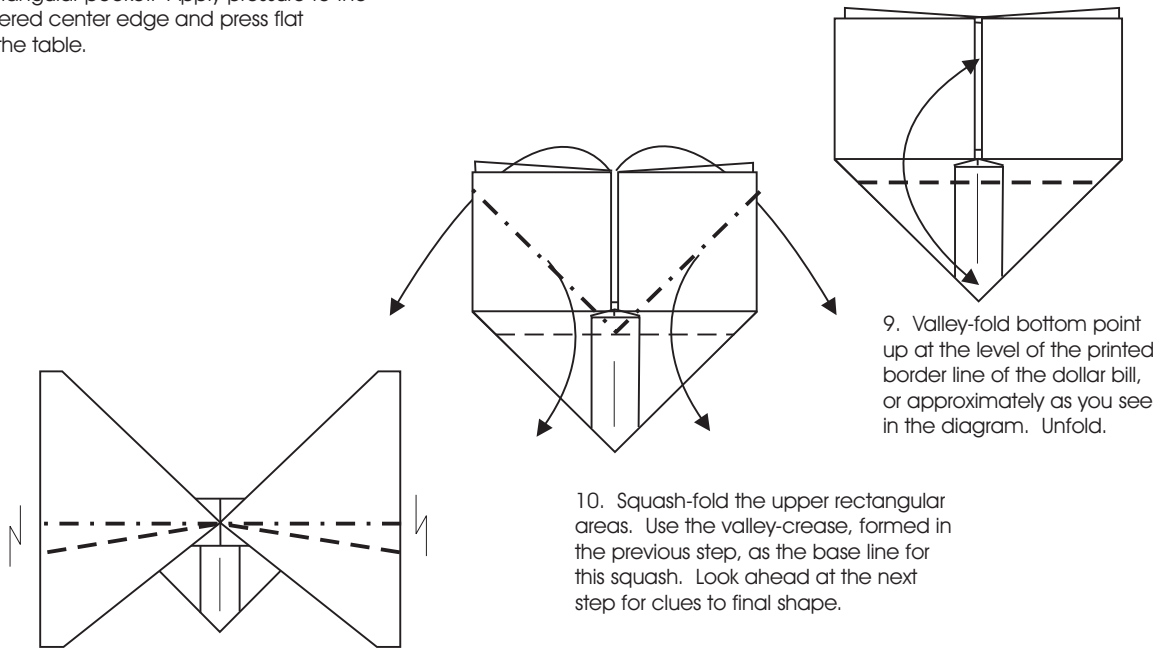

9. Valley-fold bottom point up at the level of the printed border line of the dollar bill, or approximately as you see in the diagram. Unfold.

10. Squash-fold the upper rectangular areas. Use the valley-crease, formed in the previous step, as the base line for this squash. Look ahead at the next step for clues to final shape.

11. Work one wing at a time: Make a sharp mountain-edge of the existing horizontal crease line, which runs across the center of the wing, and valley-fold the some of the lower wing paper area under this mountain-edge. This will form a wing separation line, simulating a forewing and a hindwing. The lower, or hind wing paper will change its shape when this is done. Look ahead to see the result. Repeat with the other wing.

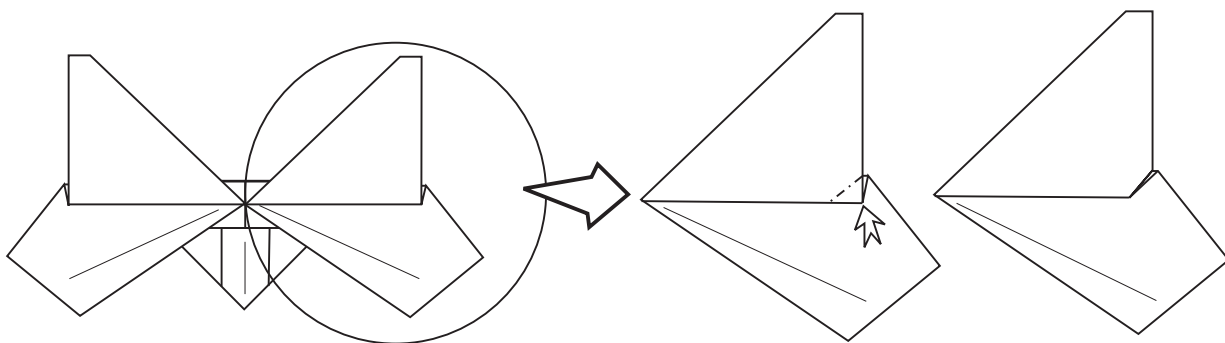

12. Give a rounded effect to the indicated corner by inside-reverse folding it. The corner paper is pushed inside the paper layers and makes a V-notch. Repeat with the other wing.

# Dollar Bill Butterfly

Designed & diagrammed by Michael G. LaFosse copyright 1995

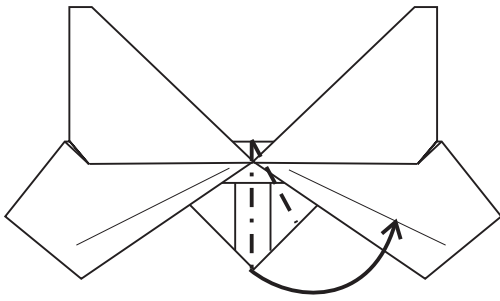

13. Swivel the abdomen point across one of the wings and align it to the mountain-crease on the hindwing section.

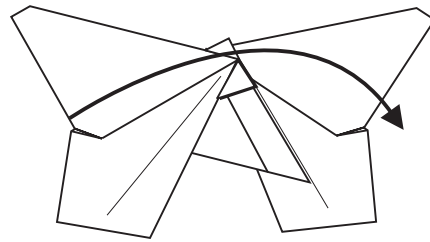

14. Fold the other wing to cover the body and to match the first wing.

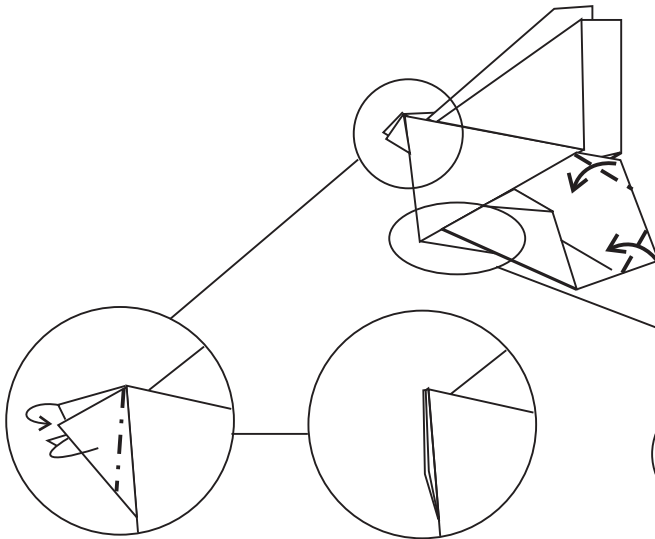

15. Valley-fold corners of wing to give a rounded effect. Repeat with the other wing.

16. Fold square corners, in the head area, inside the model.

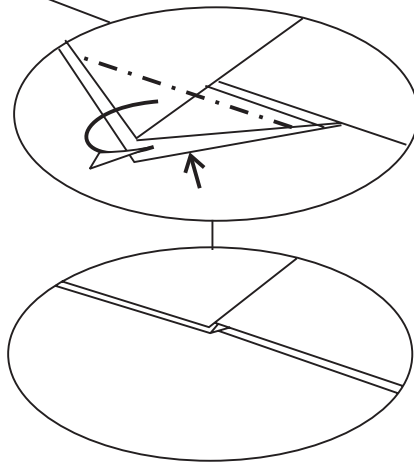

17. Fold body corners inside the model to make this area more slender. You can tuck these corners under fold-edged layers inside the underside of the body paper. The paper gets thick here so crease well.

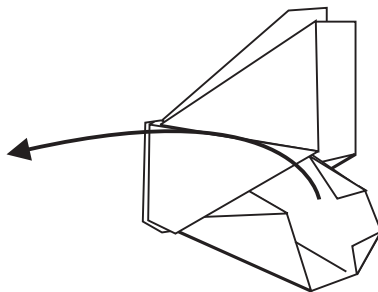

18. Open the butterfly out.

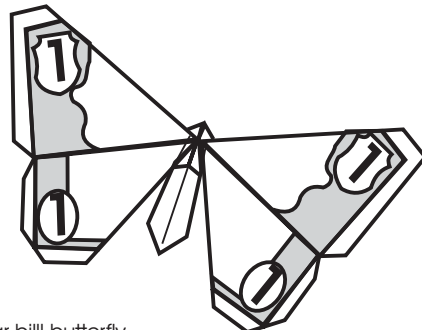

19. The finished dollar bill butterfly